

Galaxy series

MPPT Solar Controller Instructions for use



SHENZHEN IPANDEE NEW ENERGY TECHNOLOGY CO., LTD.

WWW.IPANDEE.COM



Important safety instructions (for the convenience of future use, please keep this handbook. Please read all the instructions and notes in the manual carefully before you install it).

This manual contains all the safety, installation and operation instructions of the series solar charge controller (hereinafter referred to as "controller"):

◇ Please install it indoors to avoid exposure of components and prevent water from entering the controller.

◇ This machine adopts upper and lower convection heat dissipation, please install the controller in a well-ventilated place. In order to prevent the machine from overheating, power reduction, alarming or failure and other events, during installation it must be ensured there is a space distance of more than 300mm between the upper and lower air outlets and the air inlet.

◇ The Galaxy controller is heavy. It is recommended that more than 2 people cooperate with each other during installation to avoid accidents.

◇ It is recommended that insurance or circuit breakers be connected to the input end, load end, and battery end to prevent sparks and electric shocks during cable connection and difficult disconnection when the system loop is faulty.

◇ It is strictly forbidden for the battery to fall off during the running and charging of the machine (including artificially closing the battery air switch or the battery side air switch configured with too small size and overheating and beating off, causing the battery to fall off). (It is recommended to use an air switch with a power 1.3~1.5 times higher than the rated current)

◇Before connecting cables, turn off all air switches or circuit breakers, and turn on the air switches or circuit breakers in the correct sequence (Example picture 1) :

- A. Turn on the battery switch first (battery switch/circuit breaker)
- B. Turn on the solar panel switch later (photovoltaic switch).

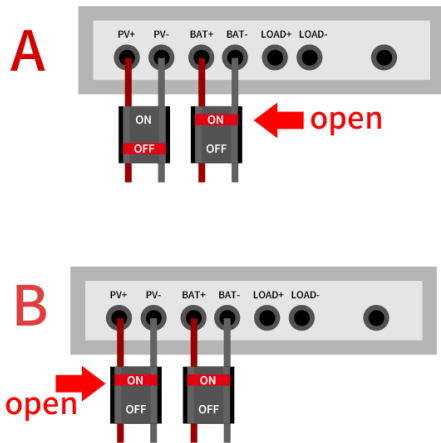

Example picture 1

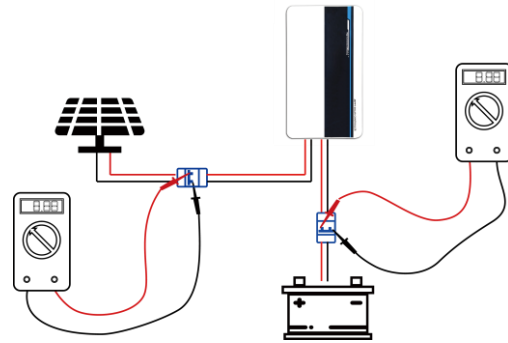

Example picture 2

◇After installation, check whether all lines are securely connected to avoid the danger due to heat accumulation caused by virtual connection; check whether the polarity of the positive and negative terminals is correct to avoid damage to the controller caused by wiring errors (some models have anti-reverse connection devices to avoid this situation, seeing the specification for details).

◇Before powering on, the battery voltage system must be checked. The solar battery voltage system must match the specifications of the machine to avoid abnormal events such as machine failure and damage (Example picture 2) .

◇The operating voltage of the product series is high. When installing the system, please ensure that the enclosure is well grounded (there is a grounding screw at the bottom of the enclosure) to avoid the danger of electric shock and other abnormal conditions during use (Example picture 3) .

◇If the indicator light is not on after the first use, cut off the fuse or circuit breaker immediately and then check whether the circuit is correctly connected.

◇When the controller is in normal charging state, do not disconnect the battery, otherwise the DC load may be damaged.

◇ Turn off the equipment in the correct order to avoid damage to the machine (Example picture 4) :

A. Turn off the solar panel switch first (photovoltaic side air switch)

B. Turn off the battery switch later (battery side air switch).



Example picture 3

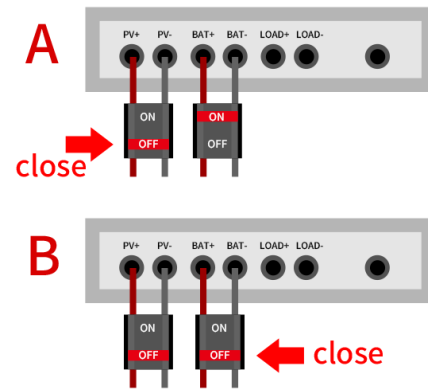

Example picture 4

size

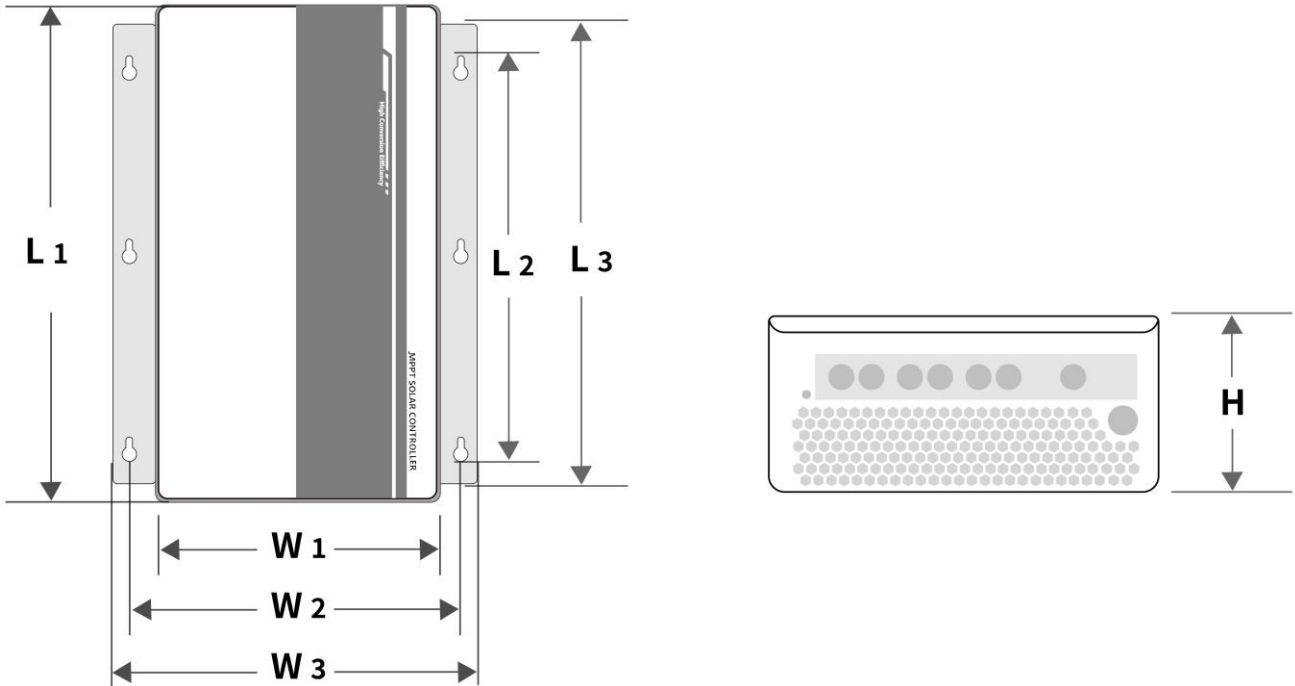

	H	L 1	L 2	L 3	W 1	W 2	W 3
Small	187mm	540mm	378mm	475mm	313mm	341mm	363mm
medium	222mm	522mm	378mm	475mm	340mm	368mm	390mm
large	227mm	680mm	378mm	475mm	450mm	478mm	500mm

Content

1. Basic information of MPPT controller	7
1.1 Product overview and features	7
1.2 Product Features	8
1.3 ProductAccessories	8
1.4 Maximum power point tracking technology	9
1.5 Battery charging phase	10
1.6 Li-ion battery charging stage	12
2. Controller installation	12
2.1 Selection of installation location	12
2.2 Safety distance	12
2.3 Notes on Controller Installation	13
3. Controller connection	13
3.1 Solar charging system connection diagram	13
3.2 The quantity of PV modules connected in series	14
3.3 Total input power of PV modules	15
3.4 Battery system voltage and its type	16
3.5 DC load output voltage system and maximum current	16
3.6 Specifications of cables and circuit breakers/air switches	17
3.7 Controller on and off steps	18
3.8 Controller communication port instruction	19
3.9 Controller communication pin definition	20
4. Operation of the controller	20
4.1 Indicators and buttons Operation	20
4.2 Introduction to the menu	20
5. Specification parameter	20
6. Maintenance and cleaning	21
6.1 Replacing the fuse	21
6.2 Cleaning the vent fins	21
7. Warranty	21
8. Warranty Card	22
9. Addendum	23
9.1 Series product conventional model specification table	23
9.2 SolarMate application APP instructions	29
9.3 service and support	29
9.4 Scan the code to download the app	29

1. Basic information of MPPT controller

1.1 Product overview and features

Thank you for choosing this series of MPPT solar charge controllers! This series of products is specially developed to match the application of high battery voltage system in the range of 96V~480V. The unique voltage overcharge protection technology can effectively prevent the risk of system damage caused by the disconnection of the battery side (breaker over heating or BMS protection of lithium batteries).

This series of products have the function of current-limited charging. When the user's photovoltaic panel power is too high, the controller automatically maintains the charging power, and the charging current will not exceed the rated value.

The design of this series of products maintains a high energy conversion efficiency under the premise of system stability as the core. With DSP as the control core and excellent algorithms and operation logic, the products have ultra-high MPPT tracking efficiency.

This series of products supports the solar charging application requirements of various lead-acid batteries and lithium battery energy storage systems. Users can easily set working parameters and read operating data through the built-in Bluetooth module of the controller using a mobile phone. This series of products supports the external connection of our WIFI cloud module, and supports the operation and maintenance of PC-side monitoring software with string communication. This series of products comes with a monitor meter, which can be used normally by connecting the plug of the monitor meter to the RJ45 interface of the controller. The function of the monitor meter is practical, the operation logic is simple, and easy to operate. With magnetic function, Meter can be stick on the controller's case .

This series of products adopts the RS485 external communication mode of RJ45 interface, users can carry out unified integrated management according to the communication protocol.

1.2 product features

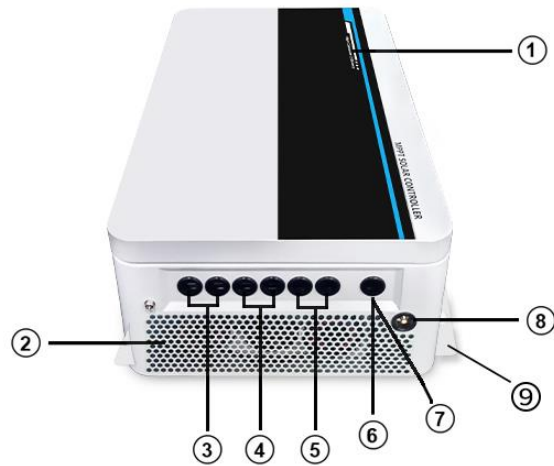

serial number	name	serial number	name
1	Working status indicator	6	Communication port
2	Heat emission hole	7	temperature sensor outlet
3	PV array wiring port	8	Antenna interface
4	Battery Wiring Port	9	Wall Mounting Strips
5	Load wiring port		

1.3 Product accessories

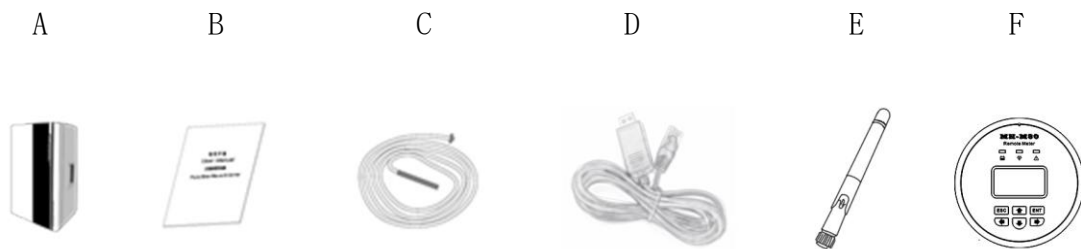

MPPT solar controller diagram

project	quantity	item
A	1 pcs	controller
B	1 pcs	User manual
C	1 pcs	temperature sensor
D	1 pcs	RS485-USB communication cable (optional)
E	1 pcs	bluetooth antenna
F	1 pcs	MH-M80 monitoring table

If accessories are missing, please contact your dealer.

1.4 Maximum Power Point Tracking Technology

Due to the nonlinearity of the solar array and the influence of the light environment, there is a maximum power output point (maximum power point) of the array on its power curve. This series of controllers has MPPT control technology, which can always track the maximum power point of the array to obtain The maximum energy to charge the battery, and the traditional controller (switch charging technology and PWM charging technology) cannot maintain the charging of the battery at this point, so it cannot obtain the maximum power from the panel;

As shown in the figure below, the curve is also the characteristic curve of the array. MPPT technology "increases" the charging current of the system by tracking the maximum power point of the array. Under the assumption that the system charging conversion efficiency is 100%, the following formula is established:

$$\begin{array}{c} \boxed{\text{Controller input power (solar panel input power)}(P_{PV}) = \text{Controller output power } (P_{Bat})} \\ \Downarrow \\ \boxed{\text{Input voltage } (V_{Mpp}) * \text{Input Current } (I_{PV}) = \text{Charging voltage } (V_{Bat}) * \text{recharging current } (I_{Bat})} \end{array}$$

Under normal circumstances, Array's V_{Mpp} is always greater than V_{Bat} , Because of the principle of conservation of energy, So I_{Bat} is always greater than I_{PV} . The more difference between V_{Mp} and V_{Bat} , then the more difference between I_{PV} and I_{Bat} , which is also the easiest way to distinguish whether it is an MPPT controller;

As shown in the figure below, it is the maximum power point tracking curve of our company's products, and the shaded part is the working range of the traditional controller. It can be clearly judged from the figure that the MPPT algorithm can effectively improve the utilization rate of the solar array. According to the test comparison, our company's MPPT controller can improve the utilization efficiency of the solar array by 20% to 60% than the PWM controller; (according to different use environments, the efficiency varies)

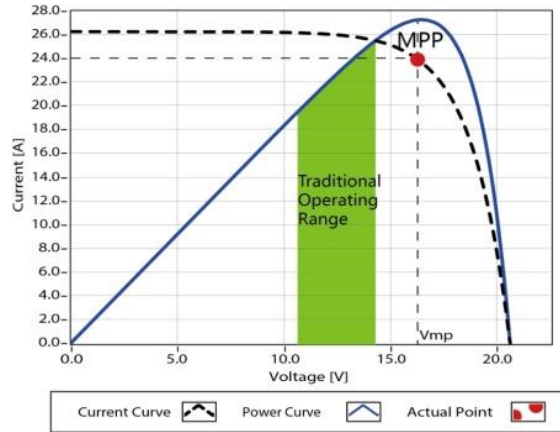

Maximum power point tracking curve

In the actual application process, due to the occlusion of clouds, branches or snow, there may be multiple MPPT points in the array, but only one of these MPPT points is the actual maximum power point, as shown in the following figure:

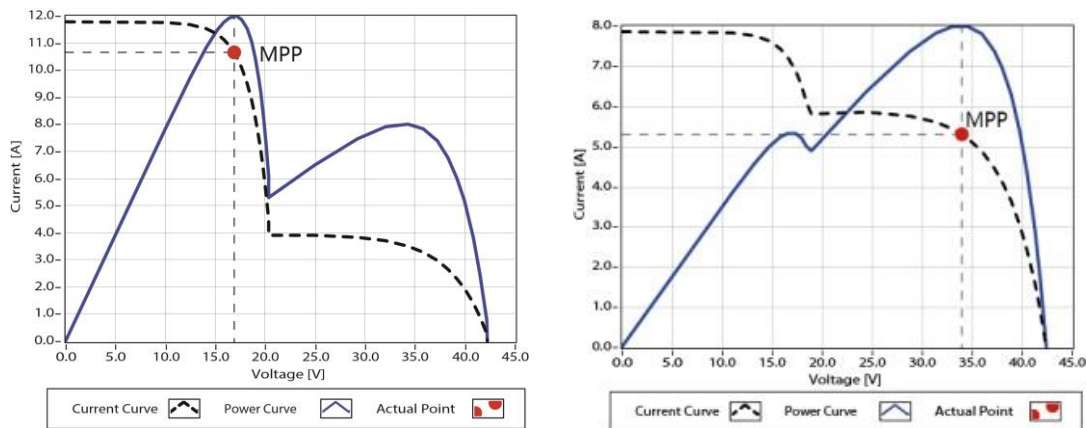

Maximum Power Point Tracking Bimodal Plot

When there are multiple MPPT points, if the MPPT algorithm is not running properly, it will lead to work on non-MPPT points. In this case, the conversion efficiency is low. The maximum power point tracking algorithm of the controller designed by our company can quickly and accurately track the The actual MPP point improves the utilization rate of the array energy and avoids the waste of energy.

1.5 Lead-acid battery charging stage

The controller performs three-stage charging methods for lead-acid batteries, namely constant current charging CC (maximum power fast charging), constant voltage charging CV and floating charging CF; through these fast, efficient and safe battery charging methods , the system can effectively prolong the service life of the battery.

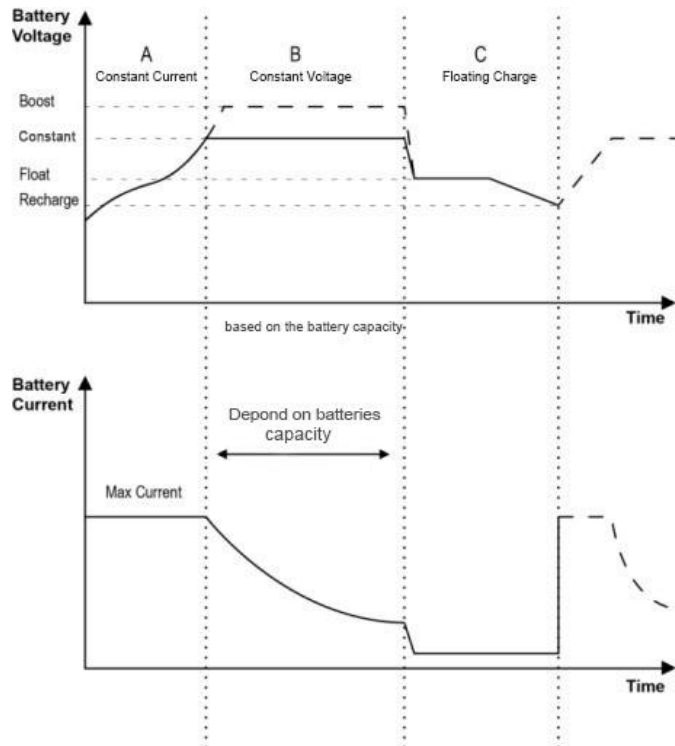

Battery charging stage indication

a) Constant Current Charge CC (Maximum Power Fast Charge)

In the fast charging stage, the battery voltage has not reached the set value of the full voltage (ie equalization/boosting voltage), the controller will perform MPPT charging, which will provide the maximum solar energy to charge the battery.

b) Constant Voltage Charge CV (Equalization Charge and Boost Charge)

When the battery voltage reaches the set value of constant voltage charging, the controller will perform constant voltage charging, and the charging current will gradually decrease over time during this process. There are two stages of maintenance charging, namely the main charging stage and the equalizing charging stage. These two charging processes will not repeat, and the equalizing charging is started on the 1st of each month.

c) Float charge CF

After the constant voltage charging stage, the controller will reduce the battery voltage by reducing the charging current and keep the battery voltage at the set value of the float charging voltage. In the float charging stage, the battery is charged in a small amount to ensure that the battery is maintained in a fully charged state. During the float charging phase, the load can obtain nearly all of the solar power. If the load exceeds the power that the solar energy can provide, the controller will not be able to maintain the battery voltage at the float stage. When the battery voltage is as low as the set value for restoring constant voltage charging, the system will exit the floating charging stage and re-enter the constant current charging stage.

1.6 Li-ion battery charging stage

According to the characteristics of the lithium-ion battery, the controller mainly charge the lithium-ion battery in two stages: maximum power fast charging (CC mode) and saturation voltage regulated charging (CV mode).

The maximum power fast charging stage is the same as the charging of lead-acid batteries, which is charged with the maximum energy that can be generated by the current photovoltaic module within the rated charging current range, until it reaches the saturation charging voltage set point and ends and enters the saturation voltage regulation charging stage. In the saturation voltage regulation charging stage, the battery voltage is constant. As the power gradually saturates, the charging current will gradually decrease until it reaches 0. The controller will maintain this state until the battery voltage drops to the set value and then jumps back to the maximum power. fast charging stage.

2. Controller installation

2.1 Choice of installation location

- ☞ The installation location should be selected away from the place easily accessible by non-professionals.

- ☞ The weight and size of the controller should be taken into account.

- ☞ The ambient temperature of the installation location must be within the range of -20°C to 50°C .

- ☞ The installation location should avoid moisture.

- ☞ The installation location needs to maintain a good ventilation environment.

- ☞ The installation location should avoid direct sunlight.

2.2 safety distance

It is recommended to observe the following safety clearances to ensure that other equipment or objects are not within this range to ensure sufficient cooling space.

illustrate	Safety distance
left and right	>300mm
up and down direction	>300mm

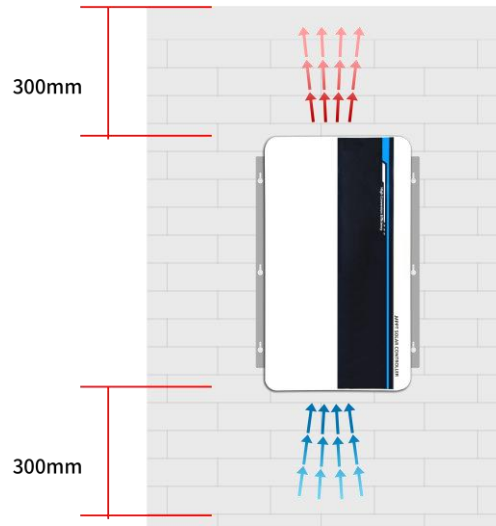

Controller installation distance

2.3 Controller Installation Precautions

Please read the safety instructions on the title page carefully before installing the controller!

3. Controller connection

3.1 Solar Charging System Connection Diagram

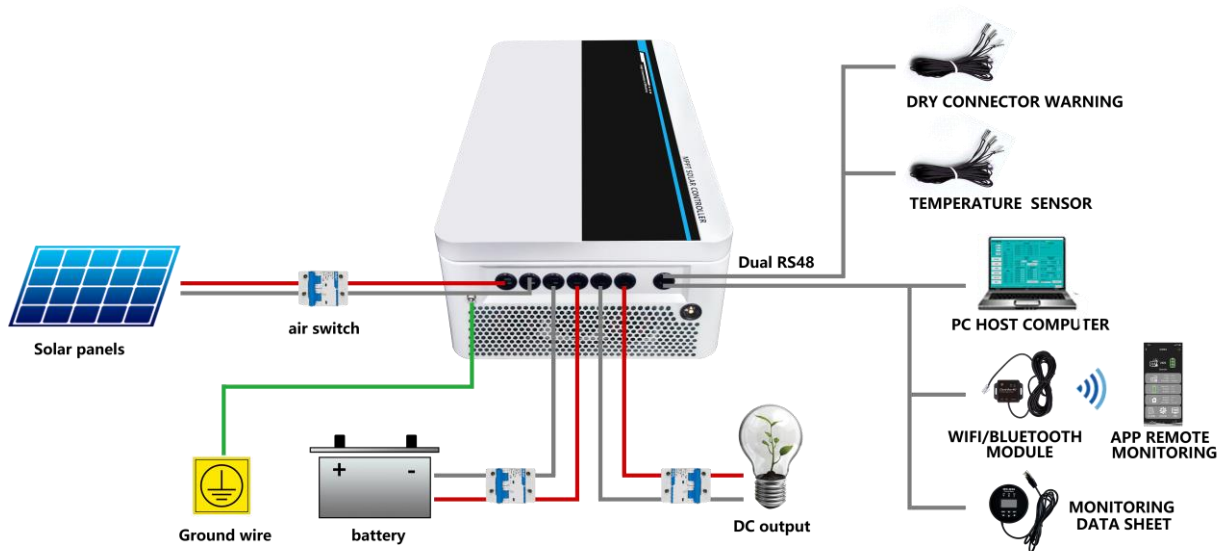

sample graph 3.1 Solar Charging

3.2 Quantity of PV modules in series

Since the types of photovoltaic modules on the market are different, it is particularly important that the controller, as the core component in the photovoltaic system, can be suitable for various types of photovoltaic modules and can maximize the conversion of solar energy into electricity. Therefore, according to the open circuit voltage of the MPPT controller (V_{oc}) and maximum power point voltage (V_{MPP}) can be used to calculate the number of photovoltaic modules in series suitable for different types. The following is a table of the quantity of photovoltaic modules in series, for reference only.

PV_{input} <DC430V The total input voltage is prohibited greater than 430V								
system voltage	36cell Voc<23V		48cell Voc<31V		54cell Voc<34V		60cell Voc<38V	
	maximum	optimal	maximum	optimal	maximum	optimal	maximum	optimal
96V	18	10~15	13	8~11	12	7~10	11	6~9
192V	18	15~18	13	11~13	12	11~12	11	10~11
216V	18	16~18	13	12~13	12	11~12	11	10~11
240V	18	17~18	13	13	12	12	11	11
system voltage	72cell Voc<46V		96cell Voc<62V		film 80V<Voc<100V			
	maximum	optimal	maximum	optimal	maximum		optimal	
96V	9	5~7	7	4~6	4		2~3	
192V	9	7~9	7	5~6	4		3	
216V	9	8~9	7	6	4		3	
240V	9	9	7	6	4		3~4	

PV_{input} <DC660V The total input voltage is prohibited greater than 660V								
system voltage	36cell Voc<23V		48cell Voc<31V		54cell Voc<34V		60cell Voc<38V	
	maximum	optimal	maximum	optimal	maximum	optimal	maximum	optimal
192V	28	17~23	21	12~17	19	11~15	17	10~13
216V	28	18~24	21	13~18	19	12~16	17	11~14
240V	28	19~25	21	14~19	19	13~17	17	12~15
system voltage	72cell Voc<46V		96cell Voc<62V		film 80V<Voc<100V			
	maximum	optimal	maximum	optimal	maximum		optimal	
192V	14	8~11	10	6~8	6		4	
216V	14	9~12	10	7~8	6		4~5	
240V	14	10~12	10	8	6		5	

PV _{input} <DC850V The total input voltage is prohibited greater than 850V								
system voltage	36cell Voc<23V		48cell Voc<31V		54cell Voc<34V		60cell Voc<38V	
	maximum	optimal	maximum	optimal	maximum	optimal	maximum	optimal
384V	36	32~36	27	24~27	25	22~25	22	19~22
480V	36	35~36	27	26~27	25	24~25	22	20~22
system voltage	72cell Voc<46V		96cell Voc<62V		film 80V<Voc<100V			
	maximum	optimal	maximum	optimal	maximum		optimal	
384V	18	16~18	13	12~13	8		7~8	
480V	18	17~18	13	13	8		8	

Note: The above parameter values are calculated under standard test conditions (STC: standard test condition 25 °C, air quality AM1.5, 1000W/square meter).

3.3 PV module input total power

This series of MPPT controllers has a charging current limit function, that is, the controller can limit the charging current within the rated charging current range of the controller, and the controller can obtain a maximum power that is not greater than the rated charging current of the controller, so even if the PV side of the controller If the input power exceeds the rated charging power of the controller, the controller will charge the battery according to the rated charging current of the controller. For example, if the rated power is 60A controller for 96V system, no matter how big the input solar panel is, the charging current will not exceed 60A.

The actual operating power of the PV array meets the following conditions:

1) When the actual power of the photovoltaic array is less than or equal to the rated charging power of the controller, the maximum charging power of the controller is the actual power of the photovoltaic array.

2) When the actual power of the photovoltaic array > the rated charging power of the controller, the controller works according to the power of the rated charging current. If the power of the photovoltaic array is greater than the rated charging power of the controller, the charging time at the rated charging current will be prolonged, so more energy can be obtained to charge the battery. At the same time, when the sun is strong, the current limiting effect will also cause the solar panel waste;

Note: Please refer to the specification table for the rated power of different types of products!

3.4 Battery system voltage and its type

1) The default of lead-acid battery is to automatically identify whether the current battery voltage is normal (Auto), and the user can also directly set the system voltage of the battery. Features of automatic identification: it can detect whether the battery voltage is within the normal range (12V single-cell battery range is between 9~15V), if it cannot be recognized normally, it will not be charged; the characteristics of the specified battery system voltage: regardless of the current battery voltage is how much will work at the specified system voltage.

2) The lithium-ion battery mode will default to a set of working parameters for commonly used lithium iron phosphate batteries. It is recommended that users reset the parameters according to their own lithium battery type and battery pack string number to avoid damage to expensive charging parameters due to wrong charging parameters. Battery.

3) The controller has set 3 kinds of conventional battery parameters in the following table for lead-acid batteries. If you need to charge other special batteries, please select the "User" type and then set it through the APP or host computer software; (voltage parameters are all 12V system parameters at 25° C, 96V system parameters*8, 192V system parameters*16, 216V system*18, 240V system*20)

Battery Type	Constant Voltage	Floating Voltage
Flooded	14.6V	13.8V
Sealed	14.4V	13.8V
Gel	14.2V	13.8V
User (setting)	C(9V~15V)	F(9V~15V)

3.5 DC load output voltage system and maximum current

This series of controllers has the DC LOAD output function, and its output voltage range is the same as the working voltage of the battery pack. If the voltage of the battery pack is 100.8V, then the current DC output voltage is 100.8V.

Users can choose to set different DC load output control modes according to different application requirements.

Remarks: Due to the difference of product models, some models can control the DC load output in different modes, and some models can only be permanently open and monitor the size of the load current and power usage.

3.6 Specifications of cables and circuit breakers/air switches

Wiring and installation must comply with national and local electrical requirements.

PV array wiring specifications:

Since the output current of the photovoltaic array is affected by the type of photovoltaic modules, connection method and illumination, the minimum wire diameter of the photovoltaic array is calculated according to the short-circuit current of the photovoltaic array. Please refer to the short-circuit current value in the PV module specification (the short-circuit current remains unchanged when the PV modules are connected in series; the short-circuit current is the sum of the short-circuit currents of all parallel-connected modules). And for the convenience of switching on and off and safety, it is recommended to install a circuit breaker. Please refer to the following table for wire and circuit breaker specification selection.

model	Rated charging current	Rated discharge current	Battery wire diameter (mm ² /AWG)	Load wire diameter (mm ² /AWG)	battery breaker
50A	50A	50A	10/7	10/7	>100A
60A	60A	60A	16/6	16/6	>100A
70A	70A	70A	20/5	20/5	>125A
80A	80A	80A	26/3	26/3	>125A
100A	100A	100A	34/2	34/2	>150A

For this series of controllers, the wiring cover needs to be opened when wiring, as shown in the figure below. After wiring is completed according to the corresponding position, cover it back and lock it at the same time;

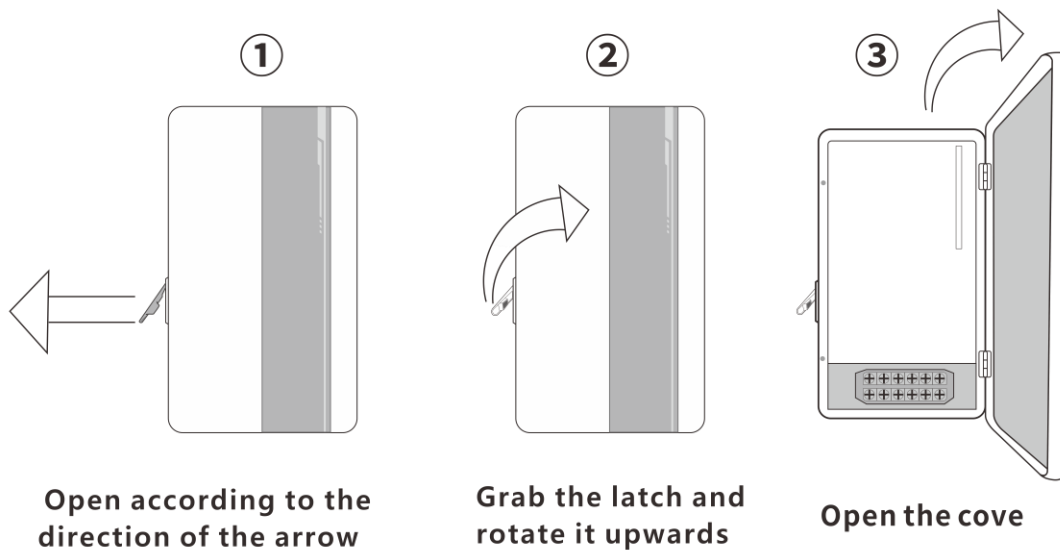

3.7 Controller on and off steps

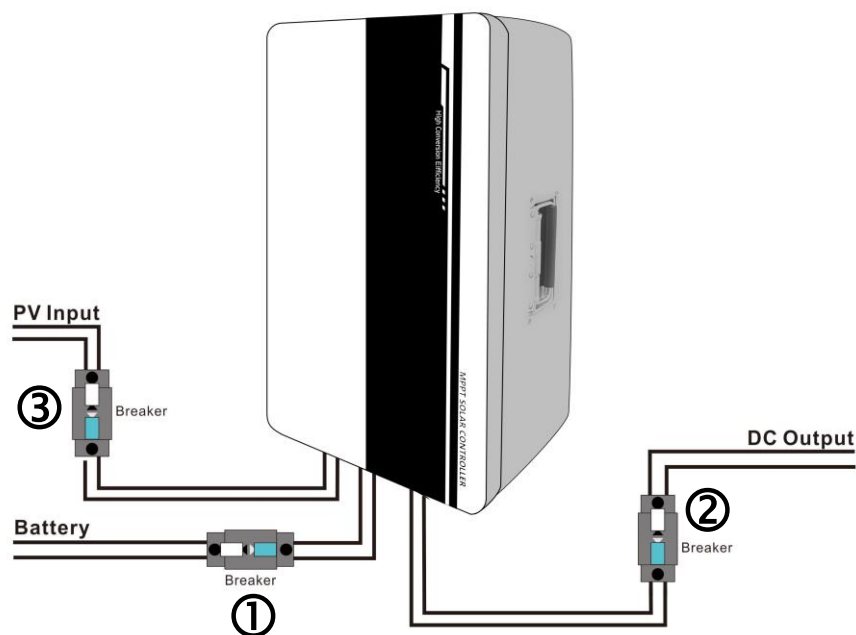

Make sure the controller is installed correctly!

Start steps:

- step 1: Turn on the circuit breaker connected to the battery first①, make sure that the controller is connected to the battery (the controller LCD will display the content), and set the battery type;
- step 2: If a DC output is required to control the load, Please set the

output control mode first, Then open the DC output "breaker"^②;
 step 3: Connect a circuit breaker that turns on the PV input of the solar panel^③, If the voltage of the PV input is within the charging operating range of the controller, the controller will enter the charging state;
 shutdown process: Turn off the "circuit breaker" in turn ^{③②①}.



warn:

1. If the system needs to connect the inverter, please connect the inverter directly to the battery, please do not connect with the load port of the controller;
2. When the controller is in a normal charging state, do not disconnect the battery, otherwise the DC load may be damaged, and the resulting damage to the controller will not be covered by the warranty.

3.8 Controller communication port instruction

The communication port of the controller can be connected to the MH-M80 monitoring meter , It can match the company's RS485-USB communication cable to realize PC-side monitoring software communication, and can also match the company's WIFI module products to realize remote APP cloud monitoring.

Note: If user uses multiple units to work in parallel the communication port will be occupied, At this time, PC-side monitoring and WIFI APP remote monitoring cannot be performed (if they are used, PC monitoring software and APP may obtain garbled data).

Distribution of communication ports of controller:

port	Function
①	Connectable meter and communication module interface with 5V power supply
②	RS485 communication interface
③	Reserved dry contact interface
④	External temperature sensor interface
⑤	Bluetooth module signal light (flashing means data is being transmitted)
⑥	Reset / restart (long press reset to restart the Bluetooth module)

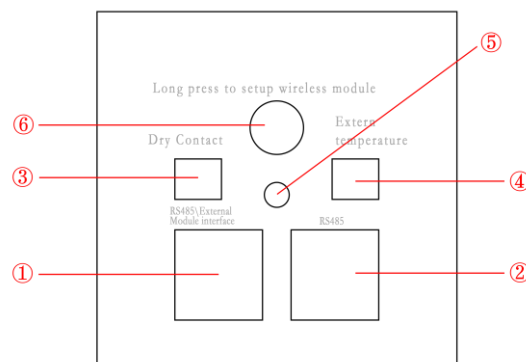

3.9 Controller communication pin definition

The communication port is a standard 8-wire RJ45 interface, the interface definition is as follows:

Tube foot	RJ45 port ①	RJ45 port ②
1	RS485-A	RS485-A
2	RS485-B	RS485-B
3	null	null
4	null	null
5	GND	null
6	GND	null
7	+5V	null
8	+5V	null

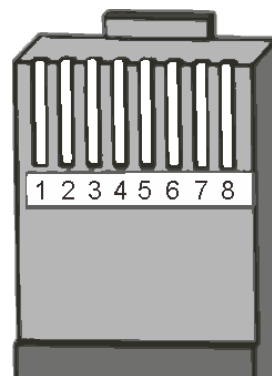

(Note: RJ45 port ① supports the host computer and MH-M80 monitoring header, RJ45 port ② only supports the host computer (external communication), and the pin definitions are only applicable to our related products!)

4. Operation of the controller

4.1 Indicator Instructions

indicator light	illustrate
yellow	The controller works in standby mode
blue	The controller is in charging state
green	DC Load is on
Red	A fault or warning is currently detected

4.2 parameter settings

Users can use the attached MH-M80 monitoring meter to set parameters. For detailed operation and use steps, please refer to the MH-M80 manual.

5. Specification parameters

(see appendix at the end of the manual)

6. maintenance and cleaning

6.1 Replace the fuse

When fuse is blown due to overheating or other faults, and the fuse needs to be replaced correctly.

Remove the broken fuse first, install a new one, then check that the connection is correct before installing the device.

6.2 Clean the vent fins

Regularly clean the fan vents and internal heat sinks, wipe with a dry or slightly damp cloth, and use a compressed air spray gun or a large blower to effectively remove accumulated dust, so that the controller always has a good working environment.

Note: Do not use washing liquid or corrosive solvent to clean, do not allow liquid to flow into the machine, and ensure that the ventilation holes of the equipment are not blocked.

7. Warranty Description

Controller within warranty period, and non-human faults can be repaired free of charge. Otherwise, a repair fee will be charged.

When returning to the agent, please pack the equipment properly to avoid damage to the equipment during transportation.

8. Warranty Card

MPPT Controller Warranty Card			
username		nation	
address		Mail	
telephone		post code	
purchase date		supplier	
installation date		Installers	
Installation Contact Information			
Controller model			
Solar Controller Serial Number			
Battery pack parameters			
Solar module parameters and configuration			
Remark			

9. Appendix

9.1 Series product conventional model specification table.

Please contact the supplier for products requiring customized special features and specifications.

Product item	GS96L60	GS96L80	GS96L100
Product Category			
Controller type	Solar Charge Controller with Maximum Power Point Tracking (MPPT)		
Maximum Power Point Tracking Efficiency	≥99.5%		
Cooling method	forced air cooling		
Lead-acid battery system voltage range	72V~120V		
Lithium-ion battery system	96V		
Input characteristics			
Maximum input voltage(Voc.Max)	430VDC		
Minimum MPPT voltage (Vmppt.min)	Vbat + 10V		
start charging voltage	Vbat + 20V		
Input overvoltage protection /recovery voltage	430VDC/425VDC		
Rated input power(W)	6240	8320	10400
Charging characteristics			
Applicable battery type	Common lead-acid batteries (SEL, GEL, FLD) and custom lead-acid batteries, custom lithium iron phosphate, ternary lithium or other lithium-ion batteries		
Rated charging current	60A	80A	100A
charging method	Lead Acid Battery: CC (Quick Charge)-CV (Constant Voltage Charge)-CF (Float Charge) Li-Ion Battery: CC (Quick Charge)-CV (Constant Voltage Charge)		
Load characteristics			
load voltage	Same as battery voltage		
Rated load current	60A	80A	100A
load control mode	On/Off, Light Control Mode, Dual Time Period Timing Control Mode, Fixed Time Light Control Mode		
Display & Communication			
Display	Working status indicator or MH-M80 meter		
communication	Dual RJ45 interface/RS485 bus/host computer software/built-in Bluetooth/WIFI module mobile phone cloud monitoring (optional)		
protocol	Standard Modbus protocol & non-standard proprietary protocol		
Other features			
How to set	PC softwar / APP /Meter		
Protections	Input / output overvoltage and undervoltage protection / input reverse connection protection / battery anti reverse connection protection / overheating protection / overcharge protection		
Operating ambient temperature	-20°C~+50°C		
Storage temperature	-40°C~+75°C		
IP(Ingress protection)	IP21		
Recommended breaker for battery	≥80A	≥100A	≥125A
net weight	17kg		
Gross weight	23.5kg		
Product Size	313*540*187MM		
Package dimensions	635*430*295MM(wooden box)		

Product item	GS120L60	GS120L80	GS120L100
Product Category			
Controller type	Solar Charge Controller with Maximum Power Point Tracking (MPPT)		
Maximum Power Point Tracking Efficiency	≥99.5%		
Cooling method	forced air cooling		
Lead-acid battery system voltage range	90V~150V		
Lithium-ion battery system	120V		
Input characteristics			
Maximum input voltage(Voc.Max)	430VDC		
Minimum MPPT voltage (Vmppt.min)	Vbat + 10V		
start charging voltage	Vbat + 20V		
Input overvoltage protection/recovery voltage	430VDC/425VDC		
Rated input power(W)	7800	10400	13000
Charging characteristics			
Applicable battery type	Common lead-acid batteries (SEL, GEL, FLD) and custom lead-acid batteries, custom lithium iron phosphate, ternary lithium or other lithium-ion batteries		
Rated charging current	60A	80A	100A
charging method	Lead Acid Battery: CC (Quick Charge)-CV (Constant Voltage Charge)-CF (Float Charge) Li-Ion Battery: CC (Quick Charge)-CV (Constant Voltage Charge)		
Load characteristics			
load voltage	Same as battery voltage		
Rated load current	60A	80A	100A
load control mode	On/Off, Light Control Mode, Dual Time Period Timing Control Mode, Fixed Time Light Control Mode		
Display & Communication			
Display	Working status indicator or MH-M80 meter		
communication	Dual RJ45 interface/RS485 bus/host computer software/built-in Bluetooth/WIFI module mobile phone cloud monitoring (optional)		
protocol	Standard Modbus protocol & non-standard proprietary protocol		
Other features			
How to set	PC softwar / APP /Meter		
Protections	Input / output overvoltage and undervoltage protection / input reverse connection protection / battery anti reverse connection protection / overheating protection / overcharge protection		
Operating ambient temperature	-20°C~+50°C		
Storage temperature	-40°C~+75°C		
IP(Ingress protection)	IP21		
Recommended breaker for battery	≥80A	≥100A	≥125A
net weight	17kg		
Gross weight	23.5kg		
Product Size	313*540*187MM		
Package dimensions	635*430*295MM(wooden box)		

Product item	GS144L60	GS144L80	GS180L60	GS180L80
Product Category				
Controller type	Solar Charge Controller with Maximum Power Point Tracking (MPPT)			
Maximum Power Point Tracking Efficiency	≥99.5%			
Cooling method	forced air cooling			
Lead-acid battery system voltage range	108V~180V		135V~225V	
Lithium-ion battery system	144V		180V	
Input characteristics				
Maximum input voltage(Voc.Max)	430VDC			
Minimum MPPT voltage (Vmppt.min)	Vbat + 10V			
start charging voltage	Vbat + 20V			
Input overvoltage protection/recovery voltage	430VDC/425VDC			
Rated input power(W)	9360	12480	11700	15600
Charging characteristics				
Applicable battery type	Common lead-acid batteries (SEL, GEL, FLD) and custom lead-acid batteries, custom lithium iron phosphate, ternary lithium or other lithium-ion batteries			
Rated charging current	60A	80A	60A	80A
charging method	Lead Acid Battery: CC (Quick Charge)-CV (Constant Voltage Charge)-CF (Float Charge) Li-Ion Battery: CC (Quick Charge)-CV (Constant Voltage Charge)			
Load characteristics				
load voltage	Same as battery voltage			
Rated load current	60A	80A	60A	80A
load control mode	On/Off, Light Control Mode, Dual Time Period Timing Control Mode, Fixed Time Light Control Mode			
Display & Communication				
Display	Working status indicator or MH-M80 meter			
communication	Dual RJ45 interface/RS485 bus/host computer software/built-in Bluetooth/WIFI module mobile phone cloud monitoring (optional)			
protocol	Standard Modbus protocol & non-standard proprietary protocol			
Other features				
How to set	PC softwar / APP / Meter			
Protections	Input / output overvoltage and undervoltage protection / input reverse connection protection / battery anti reverse connection protection / overheating protection / overcharge protection			
Operating ambient temperature	-20°C~+50°C			
Storage temperature	-40°C~+75°C			
IP(Ingress protection)	IP21			
Recommended breaker for battery	≥80A	≥100A	≥80A	≥100A
net weight	17kg			
Gross weight	23.5kg			
Product Size	313*540*187MM			
Package dimensions	635*430*295MM(wooden box)			

Product item	GS192L50	GS192L60	GS216L50	GS216L60	GS240L50	GS240L60
Product Category						
Controller type	Solar Charge Controller with Maximum Power Point Tracking (MPPT)					
Maximum Power Point Tracking Efficiency	≥99.5%					
Cooling method	forced air cooling					
Lead-acid battery system voltage range	144V~240V		162V~270V		180V~300V	
Lithium-ion battery system	192V		216V		240V	
Input characteristics						
Maximum input voltage(Voc.Max)	430VDC					
Minimum MPPT voltage (Vmppt.min)	Vbat + 10V					
start charging voltage	Vbat + 20V					
Input overvoltage protection/recovery voltage	430VDC/425VDC					
Rated input power(W)	10400	12480	11700	14040	13000	15600
Charging characteristics						
Applicable battery type	Common lead-acid batteries (SEL, GEL, FLD) and custom lead-acid batteries, custom lithium iron phosphate, ternary lithium or other lithium-ion batteries					
Rated charging current	50A	60A	50A	60A	50A	60A
charging method	Lead Acid Battery: CC (Quick Charge)-CV (Constant Voltage Charge)-CF (Float Charge) Li-Ion Battery: CC (Quick Charge)-CV (Constant Voltage Charge)					
Load characteristics						
load voltage	Same as battery voltage					
Rated load current	50A	60A	50A	60A	50A	60A
load control mode	On/Off, Light Control Mode, Dual Time Period Timing Control Mode, Fixed Time Light Control Mode					
Display & Communication						
Display	Working status indicator or MH-M80 meter					
communication	Dual RJ45 interface/RS485 bus/host computer software/built-in Bluetooth/WIFI module mobile phone cloud monitoring (optional)					
protocol	Standard Modbus protocol & non-standard proprietary protocol					
Other features						
How to set	PC softwar / APP /Meter					
Protections	Input / output overvoltage and undervoltage protection / input reverse connection protection / battery anti reverse connection protection / overheating protection / overcharge protection					
Operating ambient temperature	-20°C~+50°C					
Storage temperature	-40°C~+75°C					
IP(Ingress protection)	IP21					
Recommended breaker for battery	≥80A					
net weight	17kg					
Gross weight	23.5kg					
Product Size	313*540*187MM					
Package dimensions	635*430*295MM(wooden box)					

Product item	GS192H100	GS216H80	GS216H100	GS240H80	GS240H100
Product Category					
Controller type	Solar Charge Controller with Maximum Power Point Tracking (MPPT)				
Maximum Power Point Tracking Efficiency	99.50%				
Cooling method	forced air cooling				
Lead-acid battery system voltage range	144V~240V	162V~270V		180V~300V	
Lithium-ion battery system	192V	216V		240V	
Input characteristics					
Maximum input voltage(Voc.Max)	660VDC				
Minimum MPPT voltage (Vmppt.min)	Vbat + 10V				
start charging voltage	Vbat + 20V				
Input overvoltage protection/recovery voltage	660VDC/655VDC				
Rated input power (W)	20800	18720	23400	20800	26000
Charging characteristics					
Applicable battery type	Common lead-acid batteries (SEL, GEL, FLD) and custom lead-acid batteries, custom lithium iron phosphate, ternary lithium or other lithium-ion batteries				
Rated charging current	100A	80A	100A	80A	100A
charging method	Lead Acid Battery: CC (Quick Charge)-CV (Constant Voltage Charge)-CF (Float Charge) Li-Ion Battery: CC (Quick Charge)-CV (Constant Voltage Charge)				
Load characteristics					
load voltage	Same as battery voltage				
Rated load current	Measurable range: 0~100A				
load control mode	Normally open				
Display & Communication					
Display	Working status indicator or MH-M80 meter				
communication	Dual RJ45 interface/RS485 bus/host computer software/built-in Bluetooth/WIFI module mobile phone cloud monitoring (optional)				
protocol	Standard Modbus protocol & non-standard proprietary protocol				
Other features					
How to set	PC softwar / APP /Meter				
Protections	Input / output overvoltage and undervoltage protection / input reverse connection protection / battery anti reverse connection protection / overheating protection / overcharge protection				
Operating ambient temperature	-20°C~+50°C				
Storage temperature	-40°C~+75°C				
IP(Ingress protection)	IP21				
Recommended breaker for battery	≥125A	≥100A	≥125A	≥100A	≥125A
net weight	23kg				
Gross weight	30kg				
Product Size	340*522*222MM				
Package dimensions	620*450*335MM(wooden box)				

Product item	GS360H80	GS384H80	GS384H100	GS480H60	GS480H80
Product Category					
Controller type	Solar Charge Controller with Maximum Power Point Tracking (MPPT)				
Maximum Power Point Tracking Efficiency	99.50%				
Cooling method	forced air cooling				
Lead-acid battery system voltage range	270V~450V	288V~480V		360V~600V	
Lithium-ion battery system	360V	384V		480V	
Input characteristics					
Maximum input voltage(Voc.Max)	850VDC				
Minimum MPPT voltage (Vmppt.min)	Vbat + 10V				
start charging voltage	Vbat + 20V				
Input overvoltage protection/recovery voltage	850VDC/845VDC				
Rated input power(W)	31200	33280	41600	31200	41600
Charging characteristics					
Applicable battery type	Common lead-acid batteries (SEL, GEL, FLD) and custom lead-acid batteries, custom lithium iron phosphate, ternary lithium or other lithium-ion batteries				
Rated charging current	80A	80A	100A	60A	80A
charging method	Lead Acid Battery: CC (Quick Charge)-CV (Constant Voltage Charge)-CF (Float Charge) Li-Ion Battery: CC (Quick Charge)-CV (Constant Voltage Charge)				
Load characteristics					
load voltage	Same as battery voltage				
Rated load current	Measurable range: 0~100A				
load control mode	Normally open				
Display & Communication					
Display	Working status indicator or MH-M80 meter				
communication	Dual RJ45 interface/RS485 bus/host computer software/built-in Bluetooth/WIFI module mobile phone cloud monitoring (optional)				
protocol	Standard Modbus protocol & non-standard proprietary protocol				
Other features					
How to set	PC softwar / APP /Meter				
Protections	Input / output overvoltage and undervoltage protection / input reverse connection protection / battery anti reverse connection protection / overheating protection / overcharge protection				
Operating ambient temperature	-20°C~ +50°C				
Storage temperature	-40°C~ +75°C				
IP(Ingress protection)	IP21				
Recommended breaker for battery	≥100A	≥100A	≥125A	≥80A	≥100A
net weight	--				
Gross weight	--				
Product Size	340*585*227MM			340*585*227MM	
Package dimensions	680*450*335MM(wooden box)			680*450*335MM(wooden box)	

9.2 SolarMate application APP instructions

This APP is only suitable for use with Cloud-Box-M2 (cloud monitoring module) and BT-02 (Bluetooth module) Supporting the use of!

9.3 service and support

There are good suggestions and faults in the process of use, welcome to inquire! mygreenservice@hotmail.com

For more application videos, scan the QR code below!



9.4 Scan the code to download the app

Apple Store download



Google Play download



Web download



